



mSATA 3IE7

HIGHLIGHT FEATURES

- Up to 100K P/E cycle, extending the lifespan by 33x
- Equipped with 112-layer 3D TLC NAND Flash
- Utilizes Ultra iSLC Technology
- Supports temperatures -40°C to 85°C
- 5-year warranty

SPECIFICATIONS

Model Name	mSATA 3IE7
Flash Type	iSLC (3D TLC)
Interface	SATA III 6.0 Gb/s
Form Factor	MO-300
Capacity	20GB ~ 640GB
Sequential R / W (MB/sec, max.)	550 / 520
P/E Cycle	30,000 / 100,000
TBW (Max.)	40,000
Storage Temperature	-40°C ~ 85°C
Max. Power Consumption	1.9W
Max. Channels	4
External DRAM Buffer	N
H/W Write Protect	Y (Optional)
S.M.A.R.T.	Y
AES	Y (Optional)
TCG Opal	N
Dimension (W x L x H/mm)	29.85 x 50.8 x 3.7
Vibration	20G@[7 ~ 2000Hz]
Shock	1500G@0.5ms
MTBF	>3 million hours
Warranty	5 Years

DIAGRAM

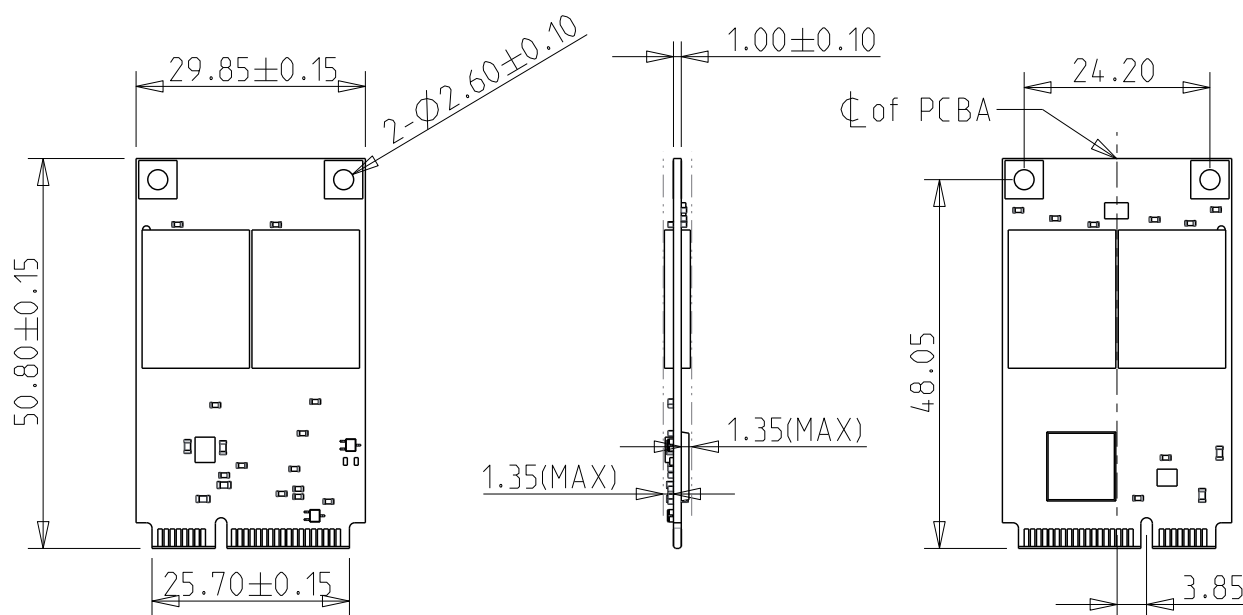

TOLERANCE: ± 0.15 mm
UNIT: mm

ORDER INFO.

Operating Temperature	Standard Grade (0°C ~ 70°C)	Industrial Grade (-40°C ~ 85°C)
20GB	DHMSR-20GDK1KCASL	DHMSR-20GDK1KWASL
40GB	DHMSR-40GDK1KCADL	DHMSR-40GDK1KWADL
80GB	DHMSR-80GDK1%CA&L	DHMSR-80GDK1%WA&L
160GB	DHMSR-A60DK1%CAQL	DHMSR-A60DK1%WAQL
320GB	DHMSR-D2GDK1%CAQL	DHMSR-D2GDK1%WAQL
640GB	DHMSR-F4GDK1KCAQL	DHMSR-F4GDK1KWAQL

%: E : 64 layers 3D TLC / K : 112 layers 3D TLC

*: PCB version control

&. S : 1 channel / D : 2 channels / Q : 4 channels

HQ (Taiwan) T +886-2-7703-3000 / E sales@innodisk.com

CN T +86-755-2167-3689 / E sales_cn@innodisk.com

US T +1-510-770-9421 / E usasales@innodisk.com

EU T +31-40-3045-400 / E eusales@innodisk.com

JP T +81-3-6667-0161 / E jp_sales@innodisk.com

innodisk